

23 SERIES OIL-LESS VACUUM PUMPS & COMPRESSORS

OPERATION & MAINTENANCE MANUAL



Model #0523-101 Shown



Model #1023-V103 Shown



Model #1023-101Q Shown

Thank you for purchasing this Gast product. It is manufactured to the highest standards using quality materials. Please follow all recommended maintenance, operational and safety instructions and you will receive years of trouble free service.



WARNING



PLEASE READ THIS MANUAL COMPLETELY BEFORE INSTALLING AND USING THIS PRODUCT. SAVE THIS MANUAL FOR FUTURE REFERENCE AND KEEP IN THE VICINITY OF THE PRODUCT.

General information

- **Model numbers ending in "X"** have automatic thermal protectors which protect the motor by shutting the motor off if it overheats. The motor will automatically restart once the motor has cooled.

Product Use Criteria:

- Pump only clean, dry air.
- Operate at 32°F - 104°F (0°C - 40°C).
- Protect unit from dirt & moisture.
- Do not pump flammable or explosive gases or use in an atmosphere that contains such gases.
- Protect all surrounding items from exhaust air. This exhaust air can become very hot.
- Corrosive gases and particulate material will damage unit. Water vapor, oil-based contaminants or other liquids must be filtered out.
- Consult your Gast Distributor before using at high altitudes.
- Oil-Less rotary-vanes require NO lubrication.
- Sealed bearings are grease packed.
- Use of petroleum or hydrocarbon products will reduce carbon-vane service life.



www.gastmfg.com

Your safety and the safety of others is extremely important.

We have provided many important safety messages in this manual and on your product. Always read and obey all safety messages.



This is the safety alert symbol. This symbol alerts you to hazards that can kill or hurt you and others. The safety alert symbol and the words "DANGER" and "WARNING" will precede all safety messages. These words mean:



DANGER

You will be killed or seriously injured if you don't follow instructions.



WARNING

You can be killed or seriously injured if you don't follow instructions.

All safety messages will identify the hazard, tell you how to reduce the chance of injury, and tell you what can happen if the safety instructions are not followed.

INSTALLATION



WARNING



Electrical Shock Hazard

Disconnect electrical power at the circuit breaker or fuse box before installing this product.

Install this product where it will not come into contact with water or other liquids.

Install this product where it will be weather protected.

Electrically ground this product.

Failure to follow these instructions can result in death, fire or electrical shock.

Correct installation is your responsibility. Make sure you have the proper installation conditions and that installation clearances do not block air flow.

Blocking air flow over the product in any way can cause the product to overheat.

Mounting

This product can be installed in any orientation. Mounting the product to a stable, rigid operating surface and using shock mounts will reduce noise and vibration.

Plumbing

Remove plugs from the IN and OUT ports. Connect with pipe and fittings that are the same size or larger than the product's threaded ports.

Accessories

The product's intake and exhaust filters will provide adequate filtration in most applications. Consult your Gast representative for additional filter recommendations. Install relief valves and gauges at inlet or outlet, or both, to monitor performance. Check valves are required to prevent back streaming through the pump.

Motor Control

It is your responsibility to contact a qualified electrician and assure that the electrical installation is adequate and in conformance with all national and local codes and ordinances.

Determine the correct overload setting required to protect the motor (see motor starter manufacturer's recommendations). Select fuses, motor protective switches or thermal protective switches to provide protection. Fuses act as short circuit protection for the motor, not as protection against overload. Incoming line fuses help to withstand the motor's starting current. Motor starters with thermal magnetic overload or circuit breakers protect motor from overload or reduced voltage conditions.

The wiring diagram attached to the product provides required electrical information. Check that power source is correct to properly operate the dual-voltage motor.

OPERATION



WARNING

Injury Hazard

Product surfaces become very hot during operation, allow product surfaces to cool before handling.

Air stream from product may contain solid or liquid material that can result in eye or skin damage, wear proper eye protection.

Failure to follow these instructions can result in burns, eye injury or other serious injury.

It is your responsibility to operate this product at recommended pressures or vacuum duties and room ambient temperatures.

Model numbers ending in "X" have automatic thermal protectors which protect the motor by shutting the motor off if it overheats. The motor will automatically restart once the motor has cooled.

Start Up

If motor fails to start or slows down significantly under load, shut off and disconnect from power supply. Check that the voltage is correct for motor and that motor is turning in the proper direction. Vane life will be drastically reduced if motor is not operating properly. Vanes can break or be damaged if motor/pump runs in the wrong direction.

MAINTENANCE

WARNING



Electrical Shock Hazard

Disconnect electrical power supply cord before performing maintenance on this product.

If product is hard wired into system, disconnect electrical power at the circuit breaker or fuse box before performing maintenance on this product.

Failure to follow these instructions can result in death, fire or electrical shock.

WARNING

Injury Hazard

Product surfaces become very hot during operation, allow product surfaces to cool before handling.

Air stream from product may contain solid or liquid material that can result in eye or skin damage, wear proper eye protection.

Flush this product in a well ventilated area.

Failure to follow these instructions can result in burns, eye injury or other serious injury.

General Maintenance

1. Remove end cap and filters. Inspect filters for rips, tears, cuts, brittleness and excessive foreign material.
2. Clean filters if in good condition with compressed air. Re-inspect for wear conditions. Set filters aside.
3. Check filter/muffler (#11) for compacted debris. If debris is present, replace filter/muffler.
4. Check condition of O-ring. It should be soft and flexible. Replace if it is not.
5. Remove and inspect muffler box. Clean box. Set box aside. (Not all models have a muffler box.)
6. Check gasket for cracks or tears. Install new gasket if any cracks or tears appear. Replace gasket.
7. Replace muffler box.
8. Reinstall filters or install new filters if required. Reinstall end cap.

Flushing

Flushing this product to remove excessive dirt, foreign particles, moisture or oil that occurs in the operating environment will help to maintain proper vane performance. There are 2 options for this operation. If Option 1 does not remedy your problem, go on to Option 2.

Use only Gast recommended flushing solvent or other non-petroleum based flushing solvent. Do Not use kerosene or ANY other combustible solvents to flush product.

Option 1

You will need 2 pipe nipples at least 4 inches long with 1/4" NPT for 0323 and 0523 products, or 3/8" NPT on one end for 0823 and 1023 products. No nipples are needed if the unit does not have a muffler box.

1. Remove filter and muffler cap (#9).
2. Remove 5 bolts. Use a small hammer to tap on muffler box to remove it. Attach pipe nipples where muffler caps were removed.
3. Start product and add flushing solvent to the inlet port. If using liquid solvent, pour several tablespoons directly into the inlet port. If using Gast recommended spray solvent, spray for 5-10 seconds into inlet port. Place towel over exhaust to clean up solvent.
4. Plug inlet port for 20-30 seconds. Listen for changes in the sound of the pump. If pump sounds smooth, go to next step. If pump does not sound like it is running smoothly, installing a Service Kit will be required (See Service).
5. Release vacuum.
6. Repeat steps 3-5 three or four times.

If Option 1 is not successful, remove the end plate and examine.

Option 2

1. Remove six end plate bolts. (See exploded view.)
2. Use a small hammer to carefully tap on end plate to remove. Do not use a screwdriver to pry off.
3. Check that vanes are moving freely in and out of vane slots. Replace vanes if more than 50% of the vane extends past the vane slot.
4. Remove vanes and clean both sides with fine emery cloth. Clean end-plate with fine emery cloth.
5. Flush vanes with Gast recommended solvent and remove all solvent from vanes.
6. Flush body, rotor and end plate with Gast recommended solvent, then remove all solvent from each part.
7. Check body, rotor and end plate for scoring. If each part is clean and shows no signs of scoring, re-install parts. If scoring appears, send unit to factory or replace with new part(s).

Check that all external accessories such as relief valves and gauges are attached to cover and are not damaged before re-operating product.

SHUTDOWN PROCEDURES

It is your responsibility to follow proper shutdown procedures to prevent product damage. NEVER ADD OIL TO THIS OIL-LESS PUMP.

1. Disconnect plumbing.
2. Operate product for at least five minutes without plumbing.
3. Run at maximum vacuum for 10-15 minutes.
4. Repeat step 2.
5. Disconnect power supply.
6. Plug open ports to prevent dirt or other contaminants from entering product.

SERVICE KIT INSTALLATION

WARNING

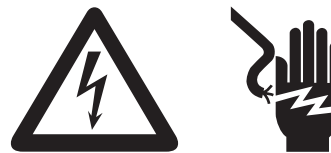

Electrical Shock Hazard

Disconnect electrical power supply cord before installing service kit.

If product is hard wired into system, disconnect electrical power at the circuit breaker or fuse box before installing service kit.

Vent all air lines to release pressure or vacuum.

Failure to follow these instructions can result in death, fire or electrical shock.

Gast will NOT guarantee field-rebuilt product performance. For performance guarantee, the product must be returned to a Gast-authorized facility.

Service Kit contents vary. Most contain vanes, gaskets and filter parts.

1. Remove filter/muffler parts from front of muffler box.
2. Remove the 5 muffler box bolts.
3. Use a small hammer to tap on box to remove. Do not use a screwdriver.
4. Remove the 6 end plate bolts.
5. Remove end plate. Check direction of bevel edges of vanes then remove vanes.
6. Clean body and rotor slots.
7. Check end plate, rotor and body for scoring. Severe scoring or worn bearings will require service at a Gast-authorized facility.

DO NOT remove rotor or motor bolts.

8. Insert vanes, checking that the bevel edges are in the correct direction.
9. Replace end plate. Torque bolts to 90-120 in. lb.
10. Check gasket for damage.
11. Reinstall muffler box. Torque bolts to 90-120 in. lb.

Check that all external accessories such as relief valves and gauges are attached and are not damaged before re-operating product.

EXPLODED PRODUCT VIEW, PARTS & ORDERING INFORMATION

REF	DESCRIPTION	QTY	0323-101	0323-101Q	0523-101	0523-101Q	0523-V103
1	BODY	1	AK503	AK503	AK505	AK505	AK505
2 *	VANE	4	AH850A	AH850A	AH850A	AH850A	AH850A
3	SHROUD	1	AK502	AK502	AK502	AK502	AK502
4	END PLATE	1	AK516A	AK501	AK516A	AK501	AK516A
5 *	GASKET	1		AK521		AK521	
6	MUFFLER BOX	1		AK519		AK519	
7 *	O-RING	2		AK473		AK473	
8 *	FELT	2		AK524		AK524	
9	END CAP	2		AK510		AK510	
10	END CAP ASSEMBLY	2		AK526		AK526	
11	FILTER / MUFFLER	1		AK840A		AK840A	
12	FOOT SUPPORT	1		AC136		AC136	
13	ELBOW ***	2					AD997
14	MUFFLER ASSEMBLY	1					V425L
15	JAR	2					AA125A
16	COVER	1					AV427A
17	FELT FILTER	4					B344A
18	SUPPORT	1					B345A
19	COVER GASKET	2					B62A
20	FILTER ASSEMBLY	1					V400G
21	COVER	1					AV402C
22	FILTER ASSEMBLY	1					B343B
23	SCREEN CAP	1					AJ571
24	FELT SUPPORT	1					B347
	SERVICE KIT	1					K559

* Denotes parts included in the Service Kit. Parts listed are for stock models.

** No Service Kit available, order parts separately. *** Not shown.

For specific OEM models, please consult the factory.

When corresponding or ordering parts, please give complete model and serial numbers.

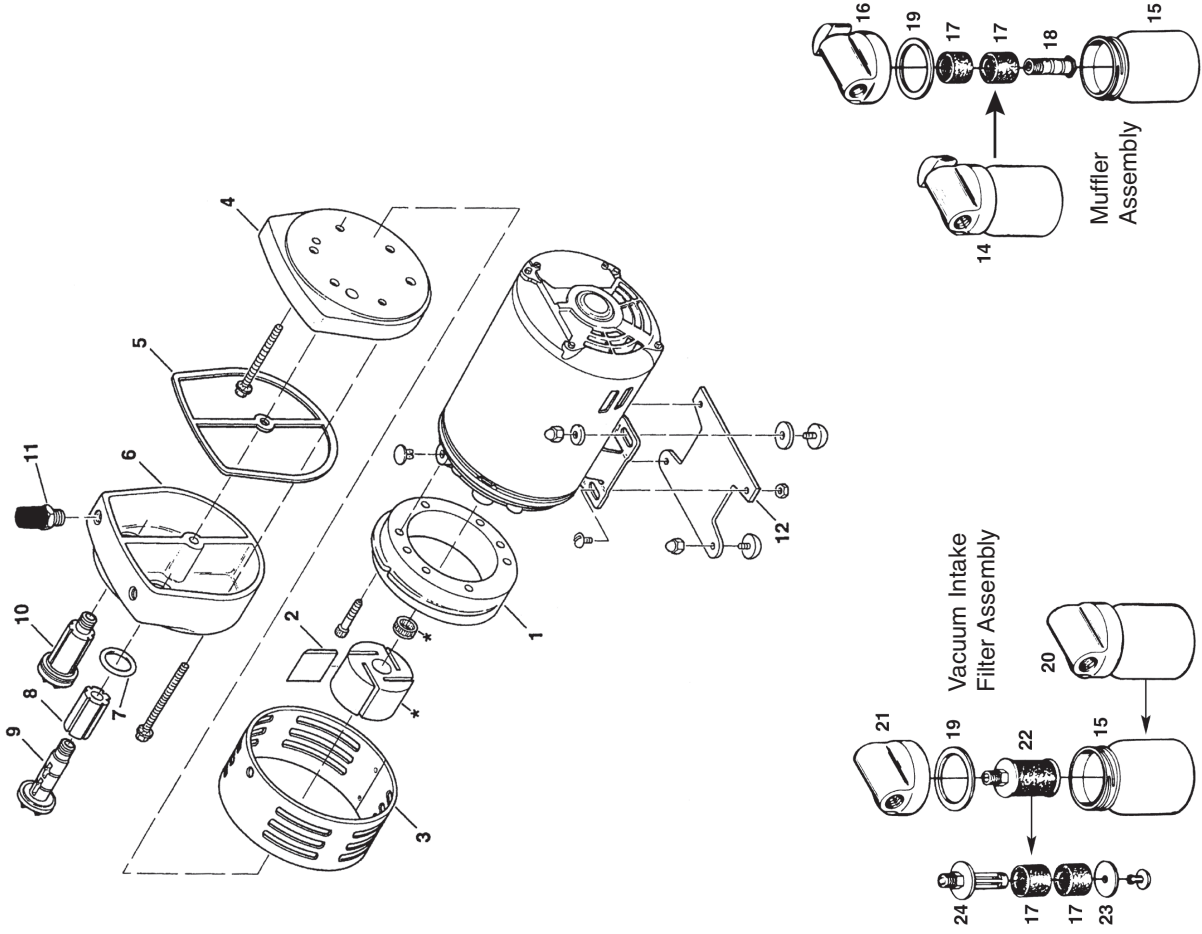

EXPLODED PRODUCT VIEW, PARTS & ORDERING INFORMATION

REF	DESCRIPTION	QTY	0823-101	0823-101Q	1023-101	1023-101Q	1023-V103	1423-101Q
1	BODY	1	AK517	AK517	AK518	AK518	AK518	AL283
2 *	VANE	4	AK513	AK513	AK513	AK513	AK513	AL284
3	SHROUD	1	AK511	AK511	AK511	AK511	AK511	AL281
4	END PLATE	1	AK515A	AK514	AK515A	AK514	AK515A	AK514
5 *	GASKET	1		AK522		AK522		AK522
6	MUFFLER BOX	1		AK520		AK520		AK520
7 *	O-RING	2		AK473		AK473		AK473
8 *	FELT	2		AK524		AK524		AK524
9	END CAP	2		AK510		AK510		AK510
10	END CAP ASSEMBLY	2		AK526		AK526		AK526
11	FILTER / MUFFLER	1		AK840		AK840		AC432
12	ELBOW	1						BA206
12	ELBOW ***	2					AF272	
13	MUFFLER ASSEMBLY	1					AB599B	
13 a	NIPPLE	2						BA714
14	JAR	2						AA805
15	COVER GASKET	2						AA405
16	COVER ASSEMBLY	1						AV805B
17	MUFFLER ASSEMBLY	1						AC434-1
18	COUPLING	2						AC391
19	CARTRIDGE	2						AC393
20	END CAP ASSEMBLY	2						AC394
21	MUFFLER PLATE	1						AC395
22	STUD	2						AC396
23	FILTER ASSEMBLY	1						AB599
24	COVER ASSEMBLY	1						AV805APC
25	FILTER ASSEMBLY	1						AC433-1
	SERVICE KIT	1	K479A	K479	K479A	K479	K479A	K575A

* Denotes parts included in the Service Kit. Parts listed are for stock models.

** No Service Kit available, order parts separately. *** Not shown.

For specific OEM models, please consult the factory. When corresponding or ordering parts, please give complete model and serial numbers.

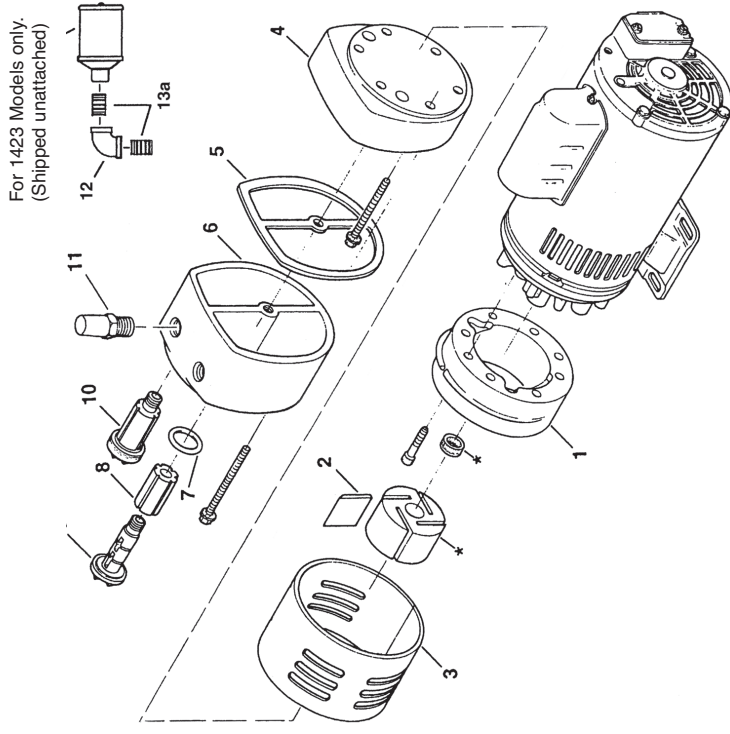

Vacuum Intake Filter Assembly

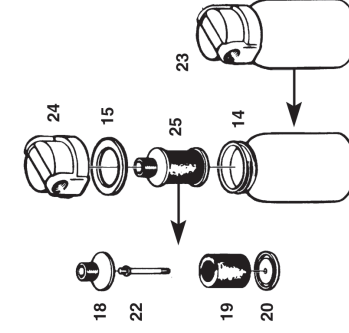

Muffler Assembly

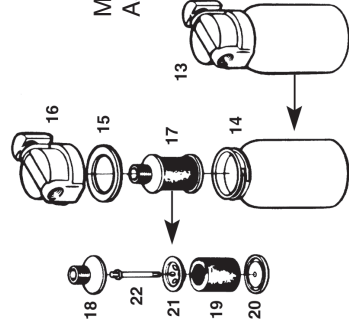

WARRANTY

Gast finished products, when properly installed and operated under normal conditions of use, are warranted by Gast to be free from defects in material and workmanship for a period of twelve (12) months from the date of purchase from Gast or an authorized Gast Representative or Distributor. In order to obtain performance under this warranty, the buyer must promptly (in no event later than thirty (30) days after discovery of the defect) give written notice of the defect to Gast Manufacturing Incorporated, 2300 M139 Highway Benton Harbor Michigan USA 49022-6114 or an authorized Service Center (unless specifically agreed upon in writing signed by both parties or specified in writing as part of a Gast OEM Quotation). Buyer is responsible for freight charges both to and from Gast in all cases.

This warranty does not apply to electric motors, electrical controls, and gasoline engines not supplied by Gast. Gast's warranties also do not extend to any goods or parts which have been subjected to misuse, lack of maintenance, neglect, damage by accident or transit damage.

THIS EXPRESS WARRANTY EXCLUDES ALL OTHER WARRANTIES OR REPRESENTATIONS EXPRESSED OR IMPLIED BY ANY LITERATURE, DATA, OR PERSON. GAST'S MAXIMUM LIABILITY UNDER THIS EXCLUSIVE REMEDY SHALL NEVER EXCEED THE COST OF THE SUBJECT PRODUCT AND GAST RESERVES THE RIGHT, AT ITS SOLE DISCRETION, TO REFUND THE PURCHASE PRICE IN LIEU OF REPAIR OR REPLACEMENT.

GAST WILL NOT BE RESPONSIBLE OR LIABLE FOR INDIRECT OR CONSEQUENTIAL DAMAGES OF ANY KIND, however arising, including but not limited to those for use of any products, loss of time, inconvenience, lost profit, labor charges, or other incidental or consequential damages with respect to persons, business, or property, whether as a result of breach of warranty, negligence or otherwise. Notwithstanding any other provision of this warranty, BUYER'S REMEDY AGAINST GAST FOR GOODS SUPPLIED OR FOR NON-DELIVERED GOODS OR FAILURE TO FURNISH GOODS, WHETHER OR NOT BASED ON NEGLIGENCE, STRICT LIABILITY OR BREACH OF EXPRESS OR IMPLIED WARRANTY IS LIMITED SOLELY, AT GAST'S OPTION, TO REPLACEMENT OF OR CURE OF SUCH NONCONFORMING OR NON-DELIVERED GOODS OR RETURN OF THE PURCHASE PRICE FOR SUCH GOODS AND IN NO EVENT SHALL EXCEED THE PRICE OR CHARGE FOR SUCH GOODS. GAST EXPRESSLY DISCLAIMS ANY WARRANTY OF MERCHANTABILITY OR FITNESS FOR A PARTICULAR USE OR PURPOSE WITH RESPECT TO THE GOODS SOLD. THERE ARE NO WARRANTIES WHICH EXTEND BEYOND THE DESCRIPTIONS SET FORTH IN THIS WARRANTY, notwithstanding any knowledge of Gast regarding the use or uses intended to be made of goods, proposed changes or additions to goods, or any assistance or suggestions that may have been made by Gast personnel.

Unauthorized extensions of warranties by the customer shall remain the customer's responsibility.

CUSTOMER IS RESPONSIBLE FOR DETERMINING THE SUITABILITY OF GAST PRODUCTS FOR CUSTOMER'S USE OR RESALE, OR FOR INCORPORATING THEM INTO OBJECTS OR APPLICATIONS WHICH CUSTOMER DESIGNS, ASSEMBLES, CONSTRUCTS OR MANUFACTURES.

This warranty can be modified only by authorized Gast personnel by signing a specific, written description of any modifications.

MAINTENANCE RECORD

DATE	PROCEDURE PERFORMED

TROUBLESHOOTING CHART

Low		High		Pump Overheat	Motor Overload	Reason and remedy for problem.
Vacuum	Pressure	Vacuum	Pressure			
•	•	At pump		•	•	Filter dirty. Clean or replace.
	•		At pump	•	•	Muffler dirty. Clean or replace.
•		At pump		•	•	Vacuum line collapsed. Repair or replace.
			•	•	•	Relief valve set too high. Inspect and adjust.
•	•					Relief valve set too low. Inspect and adjust.
•	•	At pump	At pump	•	•	Plugged vacuum/pressure line. Inspect and repair.
•	•					Vanes sticking. Clean or replace.
•	•					Vanes worn. Replace.
•	•					Shaft seal worn. Replace.
•	•			•	•	Dust or offset powder in pump. Inspect and clean.
•	•			•	•	Motor not wired correctly. Check wiring diagram and line voltage.

Gast Manufacturing, Inc.
 2300 M139 Highway
 Benton Harbor, Mi. 49022-6114
 Phone: 269-926-6171
 www.gastmfg.com

Gast Jun-Air Europe BV
 Hengelderweg 24,
 NL-6942 NB, Didam
 Netherlands
 Phone: +44 (0)1527 504040
 www.gastmfg.com

IDEX Technology (Suzhou) Co., Ltd
 No.51 TangBang Road
 CaoHu Boulevard
 Xiang Cheng District
 Suzhou, China 215131
 Phone: (86) 512 6283 3000

